

LM22677/LM22677Q

42V, 5A SIMPLE SWITCHER®, Step-Down Voltage Regulator with Features

General Description

The LM22677 switching regulator provides all of the functions necessary to implement an efficient high voltage step-down (buck) regulator using a minimum of external components. This easy to use regulator incorporates a 42V N-channel MOSFET switch capable of providing up to 5A of load current. Excellent line and load regulation along with high efficiency (>90%) are featured. Voltage mode control offers short minimum on-time, allowing the widest ratio between input and output voltages. Internal loop compensation means that the user is free from the tedious task of calculating the loop compensation components. Fixed 5V output and adjustable output voltage options are available. The default switching frequency is set at 500 kHz allowing for small external components and good transient response. In addition, the frequency can be adjusted over a range of 200 kHz to 1MHz with a single external resistor. The internal oscillator can be synchronized to a system clock or to the oscillator of another regulator. A precision enable input allows simplification of regulator control and system power sequencing. In shutdown mode the regulator draws only 25 μ A (typ.). The LM22677 also has built in thermal shutdown, and current limiting to protect against accidental overloads.

The LM22677 is a member of Texas Instruments' SIMPLE SWITCHER™ family. The SIMPLE SWITCHER™ concept provides for an easy to use complete design using a minimum number of external components and the TI WEBENCH® design tool. TI's WEBENCH® tool includes features such as external component calculation, electrical simulation, thermal simulation, and Build-It boards for easy design-in.

Features

- Wide input voltage range: 4.5V to 42V
- Internally compensated voltage mode control
- Stable with low ESR ceramic capacitors
- 100 m Ω N-channel MOSFET
- Output voltage options:
 - ADJ (outputs as low as 1.285V)
 - 5.0 (output fixed to 5V)
- \pm 1.5% feedback reference accuracy
- 500 kHz default switching frequency
- Adjustable switching frequency and synchronization
- -40°C to 125°C operating junction temperature range
- Precision enable pin
- Integrated boot-strap diode
- Integrated soft-start
- Fully WEBENCH® enabled
- LM22677Q is an Automotive Grade product that is AEC-Q100 grade 1 qualified (-40°C to +125°C operating junction temperature)

Package

- TO-263 THIN (Exposed Pad)

Applications

- Industrial Control
- Telecom and Datacom Systems
- Embedded Systems
- Conversions from Standard 24V, 12V and 5V Input Rails

Simplified Application Schematic

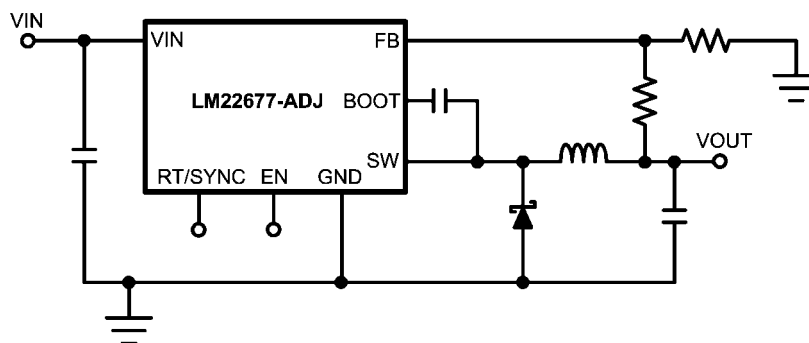

30074101

Connection Diagram

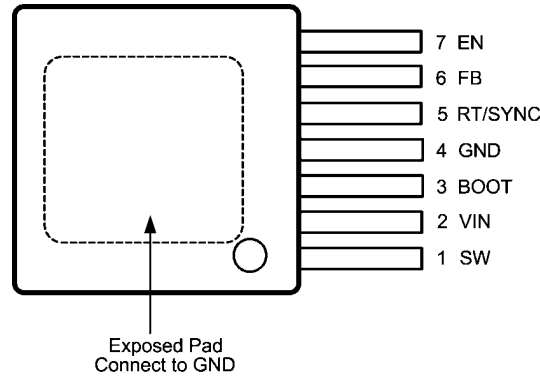

7-Lead Plastic TO-263 THIN Package
TI Package Number TJ7A

30074102

Ordering Information

Output Voltage	Order Number	Package Type	TI Package Drawing	Supplied As	Features
ADJ	LM22677TJE-ADJ	TO-263 THIN Exposed Pad	TJ7A	250 Units in Tape and Reel	
ADJ	LM22677TJ-ADJ			1000 Units in Tape and Reel	
5.0	LM22677TJE-5.0			250 Units in Tape and Reel	
5.0	LM22677TJ-5.0			1000 Units in Tape and Reel	
ADJ	LM22677QTJE-ADJ	TO-263 THIN Exposed Pad	TJ7A	250 Units in Tape and Reel	AEC-Q100 Grade 1 qualified. Automotive Grade Production Flow*
ADJ	LM22677QTJ-ADJ			1000 Units in Tape and Reel	
5.0	LM22677QTJE-5.0			250 Units in Tape and Reel	
5.0	LM22677QTJ-5.0			1000 Units in Tape and Reel	

*Automotive Grade (Q) product incorporates enhanced manufacturing and support processes for the automotive market, including defect detection methodologies. Reliability qualification is compliant with the requirements and temperature grades defined in the AEC-Q100 standard. Automotive grade products are identified with the letter Q. For more information go to <http://www.ti.com/automotive>.

Pin Descriptions

Pin	Name	Description	Application Information
1	SW	Switch output	Switching output of regulator.
2	VIN	Input voltage	Supply input to the regulator.
3	BOOT	Bootstrap input	Provides the gate voltage for the high side NFET
4	GND	Ground input to regulator; system common	System ground pin.
5	RT/SYNC	Oscillator mode control input	Used to control oscillator mode of regulator. See Frequency Adjustment and Synchronization section of data sheet.
6	FB	Feedback input	Feedback input to regulator.
7	EN	Enable input	Used to control regulator start-up and shutdown. See Precision Enable section of data sheet.
EP	EP	Exposed Pad	Connect to ground. Provides thermal connection to PCB. See applications information.

Absolute Maximum Ratings (Note 1)

If Military/Aerospace specified devices are required, please contact the Texas Instruments Sales Office/ Distributors for availability and specifications.

V _{IN} to GND	43V
EN Pin Voltage	-0.5V to 6V
RT/SYNC Pin Voltage	-0.5V to 7V
SW to GND (Note 2)	-5V to V _{IN}
BOOT Pin Voltage	V _{SW} + 7V
FB Pin Voltage	-0.5V to 7V
Power Dissipation	Internally Limited

Junction Temperature 150°C

For soldering specifications, refer to the following document: www.ti.com/lit/snoa549

ESD Rating (Note 3)

Human Body Model ±2 kV
Storage Temperature Range -65°C to +150°C

Operating Ratings (Note 1)

Supply Voltage (V_{IN}) 4.5V to 42V
Junction Temperature Range -40°C to +125°C

Electrical Characteristics Limits in standard type are for T_J = 25°C only; limits in **boldface type** apply over the junction temperature (T_J) range of -40°C to +125°C. Minimum and Maximum limits are guaranteed through test, design, or statistical correlation. Typical values represent the most likely parametric norm at T_A = T_J = 25°C, and are provided for reference purposes only. Unless otherwise specified: V_{IN} = 12V.

Symbol	Parameter	Conditions	Min (Note 5)	Typ (Note 4)	Max (Note 5)	Units
LM22677-5.0						
V _{FB}	Feedback Voltage	V _{IN} = 8V to 42V	4.925/4.9	5.0	5.075/5.1	V
LM22677-ADJ						
V _{FB}	Feedback Voltage	V _{IN} = 4.7V to 42V	1.266/1.259	1.285	1.304/1.311	V
All Output Voltage Versions						
I _Q	Quiescent Current	V _{FB} = 5V		3.4	6	mA
I _{STDBY}	Standby Quiescent Current	EN Pin = 0V		25	40	μA
I _{CL}	Current Limit		6.0/5.75	7.1	8.4/8.75	A
I _L	Output Leakage Current	V _{IN} = 42V, EN Pin = 0V, V _{SW} = 0V		0.2	2	μA
		V _{SW} = -1V		0.1	3	μA
R _{DS(ON)}	Switch On-Resistance			0.1	0.14/0.2	Ω
f _O	Oscillator Frequency		400	500	600	kHz
T _{OFFMIN}	Minimum Off-time		100	200	300	ns
T _{ONMIN}	Minimum On-time			100		ns
I _{BIAS}	Feedback Bias Current	V _{FB} = 1.3V (ADJ Version Only)		230		nA
V _{EN}	Enable Threshold Voltage	Falling	1.3	1.6	1.9	V
V _{ENHYST}	Enable Voltage Hysteresis			0.6		V
I _{EN}	Enable Input Current	EN Input = 0V		6		μA
F _{SYNC}	Maximum Synchronization Frequency	V _{SYNC} = 3.5V, 50% duty-cycle		1		MHz
V _{SYNC}	Synchronization Threshold Voltage			1.75		V
T _{SD}	Thermal Shutdown Threshold			150		°C
θ _{JA}	Thermal Resistance	T _J Junction to ambient thermal resistance (Note 6)		22		°C/W

Note 1: Absolute Maximum Ratings indicate limits beyond which damage to the device may occur, including inoperability and degradation of device reliability and/or performance. Functional operation of the device and/or non-degradation at the Absolute Maximum Ratings or other conditions beyond those indicated in the recommended Operating Ratings is not implied. The recommended Operating Ratings indicate conditions at which the device is functional and should not be operated beyond such conditions.

Note 2: The absolute maximum specification of the 'SW to GND' applies to DC voltage. An extended negative voltage limit of -10V applies to a pulse of up to 50 ns.

Note 3: ESD was applied using the human body model, a 100 pF capacitor discharged through a 1.5 kΩ resistor into each pin.

Note 4: Typical values represent most likely parametric norms at the conditions specified and are not guaranteed.

Note 5: Min and Max limits are 100% production tested at 25°C. Limits over the operating temperature range are guaranteed through correlation using Statistical Quality Control (SQC) methods. Limits are used to calculate TI's Average Outgoing Quality Level (AOQL).

Note 6: The value of θ_{JA} for the TO-263 THIN (TJ) package of 22°C/W is valid if package is mounted to 1 square inch of copper. The θ_{JA} value can range from 20 to 30°C/W depending on the amount of PCB copper dedicated to heat transfer. See application note AN-1797 for more information.

Typical Performance Characteristics Unless otherwise specified the following conditions apply: $V_{in} = 12V$, $T_J = 25^\circ C$.

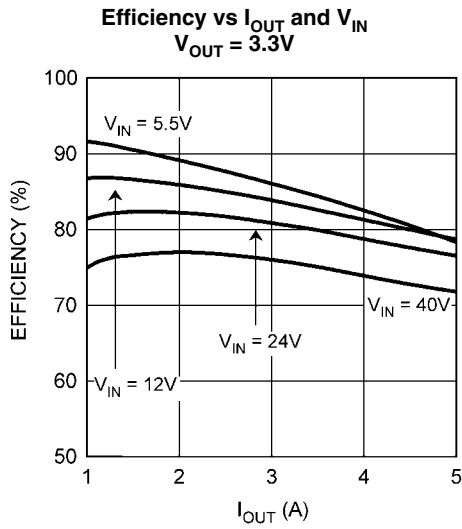

30074127

Normalized Switching Frequency vs Temperature

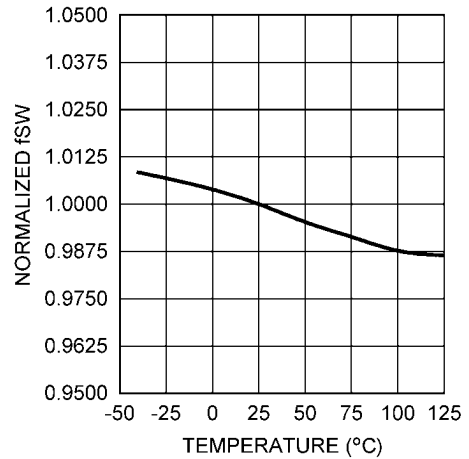

30074104

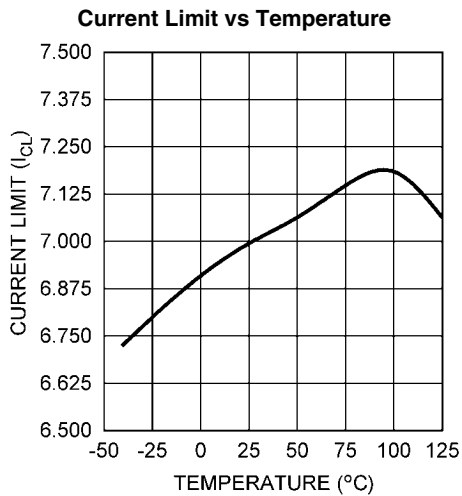

30074103

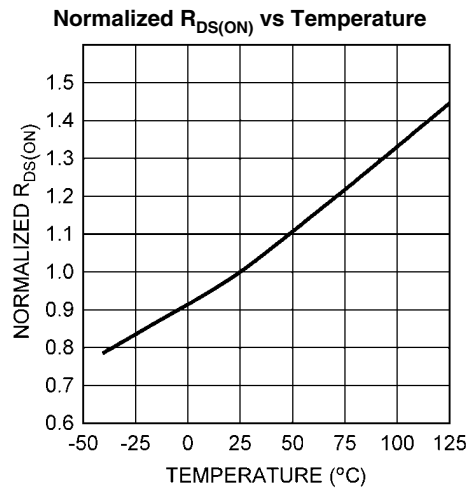

30074108

Feedback Bias Current vs Temperature

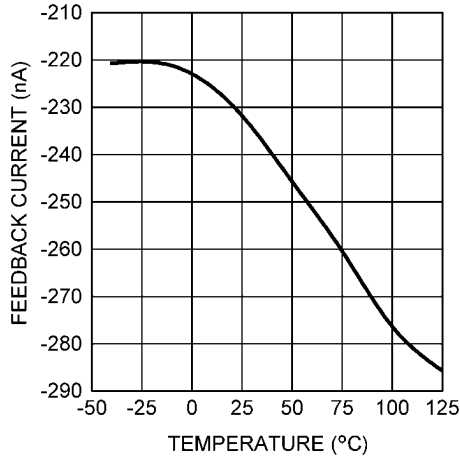

30074105

Normalized Enable Threshold Voltage vs Temperature

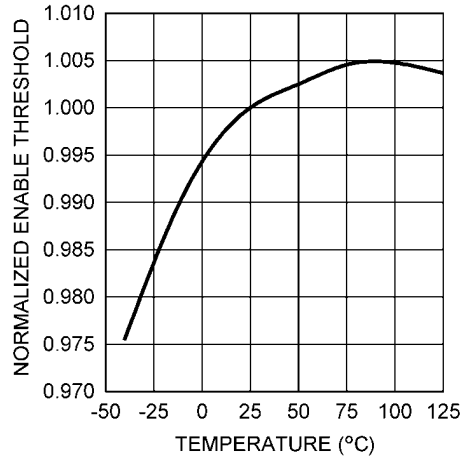

30074110

Standby Quiescent Current vs Input Voltage

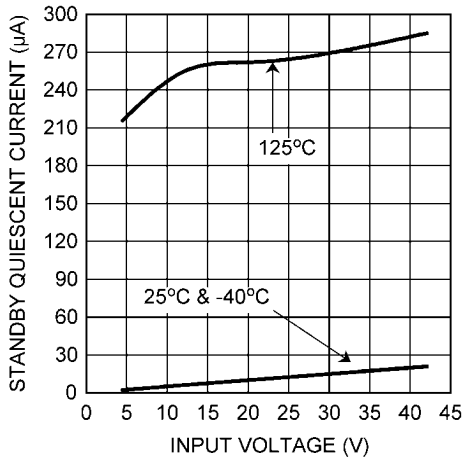

30074106

Normalized Feedback Voltage vs Temperature

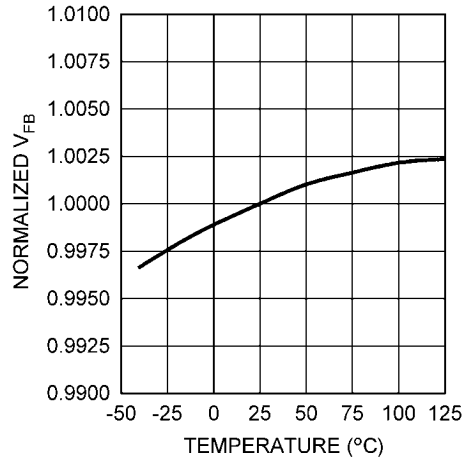

30074107

Normalized Feedback Voltage vs Input Voltage

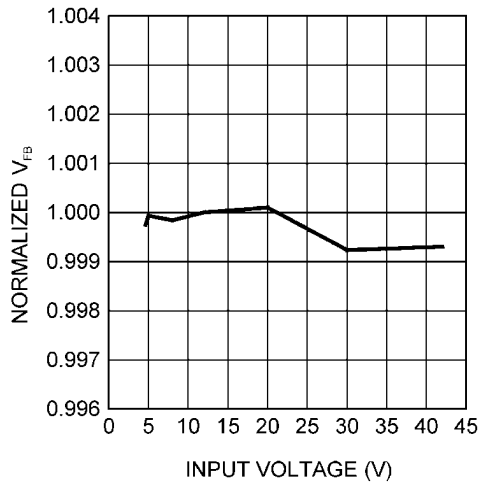

30074109

Switching Frequency vs RT/SYNC Resistor

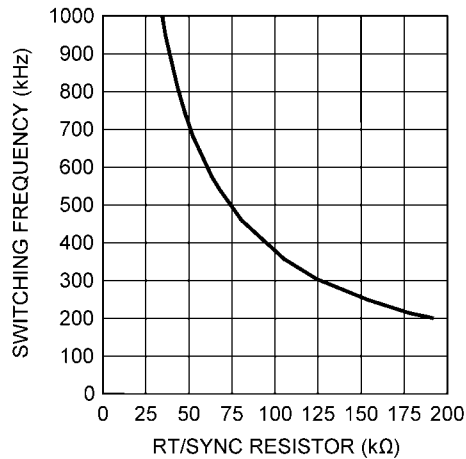

30074113

Simplified Block Diagram

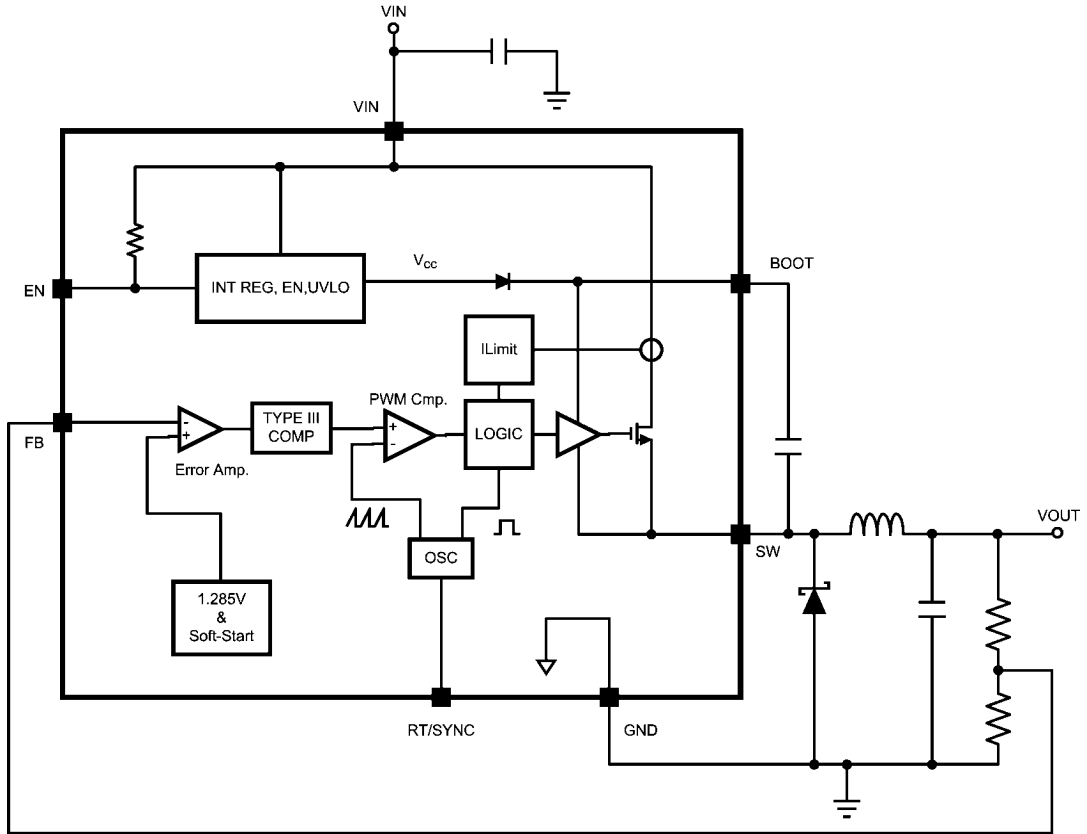

30074181

FIGURE 1. Simplified Block Diagram

Detailed Operating Description

The LM22677 incorporates a voltage mode constant frequency PWM architecture. In addition, input voltage feed-forward is used to stabilize the loop gain against variations in input voltage. This allows the loop compensation to be optimized for transient performance. The power MOSFET, in conjunction with the diode, produce a rectangular waveform at the switch pin, that swings from about zero volts to V_{IN} . The inductor and output capacitor average this waveform to become the regulator output voltage. By adjusting the duty cycle of this waveform, the output voltage can be controlled. The error amplifier compares the output voltage with the internal reference and adjusts the duty cycle to regulate the output at the desired value.

The internal loop compensation of the -ADJ option is optimized for outputs of 5V and below. If an output voltage of 5V or greater is required, the -5.0 option can be used with an external voltage divider. The minimum output voltage is equal to the reference voltage; 1.285V (typ.).

The functional block diagram of the LM22677 is shown in [Figure 1](#).

Precision Enable and UVLO

The precision enable input (EN) is used to control the regulator. The precision feature allows simple sequencing of multiple power supplies with a resistor divider from another supply. Connecting this pin to ground or to a voltage less than 1.6V (typ.) will turn off the regulator. The current drain from the input supply, in this state, is 25 μ A (typ.) at an input voltage of 12V. The EN input has an internal pull-up of about 6 μ A. Therefore this pin can be left floating or pulled to a voltage greater than 2.2V (typ.) to turn the regulator on. The hysteresis on this input is about 0.6V (typ.) above the 1.6V (typ.) threshold. When driving the enable input, the voltage must never exceed the 6V absolute maximum specification for this pin.

Although an internal pull-up is provided on the EN pin, it is good practice to pull the input high, when this feature is not used, especially in noisy environments. This can most easily be done by connecting a resistor between V_{IN} and the EN pin. The resistor is required, since the internal zener diode, at the EN pin, will conduct for voltages above about 6V. The current in this zener must be limited to less than 100 μ A. A resistor of 470 k Ω will limit the current to a safe value for input voltages as high as 42V. Smaller values of resistor can be used at lower input voltages.

The LM22677 also incorporates an input under voltage lock-out (UVLO) feature. This prevents the regulator from turning on when the input voltage is not great enough to properly bias the internal circuitry. The rising threshold is 4.3V (typ.) while the falling threshold is 3.9V (typ.). In some cases these thresholds may be too low to provide good system performance. The solution is to use the EN input as an external UVLO to disable the part when the input voltage falls below a lower boundary. This is often used to prevent excessive battery discharge or early turn-on during start-up. This method is also recommended to prevent abnormal device operation in applications where the input voltage falls below the minimum of 4.5V. [Figure 2](#) shows the connections to implement this method of UVLO. The following equations can be used to determine the correct resistor values:

$$R_{ENT} = R_{ENB} \cdot \left(\frac{V_{off}}{V_{EN}} - 1 \right)$$

$$V_{on} = V_{off} \cdot \left(\frac{V_{EN} + V_{ENHYST}}{V_{EN}} \right)$$

Where V_{off} is the input voltage where the regulator shuts off, and V_{on} is the voltage where the regulator turns on. Due to the 6 μ A pull-up, the current in the divider should be much larger than this. A value of 20 k Ω , for R_{ENB} is a good first choice. Also, a zener diode may be needed between the EN pin and ground, in order to comply with the absolute maximum ratings on this pin.

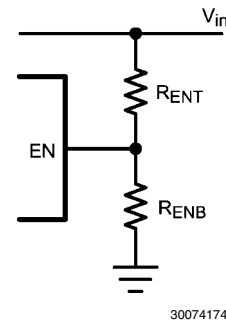

FIGURE 2. External UVLO Connections

Duty-Cycle Limits

Ideally the regulator would control the duty cycle over the full range of zero to one. However due to inherent delays in the circuitry, there are limits on both the maximum and minimum duty cycles that can be reliably controlled. This in turn places limits on the maximum and minimum input and output voltages that can be converted by the LM22677. A minimum on-time is imposed by the regulator in order to correctly measure the switch current during a current limit event. A minimum off-time is imposed in order the re-charge the bootstrap capacitor. The following equation can be used to determine the approximate maximum input voltage for a given output voltage:

$$V_{in|_{max}} \approx \frac{V_{out} + 0.4}{T_{on} \cdot F_{sw} \cdot 1.8}$$

Where F_{sw} is the switching frequency and T_{on} is the minimum on-time; both found in the Electrical Characteristics table. If the frequency adjust feature is used, that value should be used for F_{sw} . Nominal values should be used. The worst case is lowest output voltage, and highest switching frequency. If this input voltage is exceeded, the regulator will skip cycles, effectively lowering the switching frequency. The consequences of this are higher output voltage ripple and a degradation of the output voltage accuracy.

The second limitation is the maximum duty cycle before the output voltage will "dropout" of regulation. The following equation can be used to approximate the minimum input voltage before dropout occurs:

$$V_{in|_{min}} \approx \frac{V_{out} + 0.4 + I_{out} \cdot R_L}{1 - T_{off} \cdot F_{sw} \cdot 1.8} + I_{out} \cdot R_{dson}$$

The values of T_{OFF} and $R_{DS(ON)}$ are found in the Electrical Characteristics table. The worst case here is highest switching frequency and highest load. In this equation, R_L is the D.C. inductor resistance. Of course, the lowest input voltage to the regulator must not be less than 4.5V (typ.).

Current Limit

The LM22677 has current limiting to prevent the switch current from exceeding safe values during an accidental overload on the output. This peak current limit is found in the Electrical Characteristics table under the heading of I_{CL} . The maximum load current that can be provided, before current limit is reached, is determined from the following equation:

$$I_{out|_{max}} \approx I_{CL} - \frac{(V_{in} - V_{out}) \cdot V_{out}}{2 \cdot L \cdot F_{sw} \cdot V_{in}}$$

Where L is the value of the power inductor.

When the LM22677 enters current limit, the output voltage will drop and the peak inductor current will be fixed at I_{CL} at the end of each cycle. The switching frequency will remain constant while the duty cycle drops. The load current will not remain constant, but will depend on the severity of the overload and the output voltage.

For very severe overloads ("short-circuit"), the regulator changes to a low frequency current foldback mode of operation. The frequency foldback is about 1/5 of the nominal switching frequency. This will occur when the current limit trips before the minimum on-time has elapsed. This mode of operation is used to prevent inductor current "run-away", and is associated with very low output voltages when in overload. The following equation can be used to determine what level of output voltage will cause the part to change to low frequency current foldback:

$$V_x \leq V_{in} \cdot F_{sw} \cdot T_{on} \cdot 1.8$$

Where F_{sw} is the normal switching frequency and V_{in} is the maximum for the application. If the overload drives the output voltage to less than or equal to V_x , the part will enter current foldback mode. If a given application can drive the output voltage to $\leq V_x$, during an overload, then a second criterion must be checked. The next equation gives the maximum input voltage, when in this mode, before damage occurs:

$$V_{in} \leq \frac{V_{sc} + 0.4}{T_{on} \cdot F_{sw} \cdot 0.36}$$

Where V_{sc} is the value of output voltage during the overload and F_{sw} is the normal switching frequency. **If the input voltage should exceed this value, while in foldback mode, the regulator and/or the diode may be damaged.** It is important to note that the voltages in these equations are measured at the inductor. Normal trace and wiring resistance will cause the voltage at the inductor to be higher than that at a remote load. Therefore, even if the load is shorted with zero volts across its terminals, the inductor will still see a finite voltage. It is this value that should be used for V_x and V_{sc} in the calculations. In order to return from foldback mode, the load must be re-

duced to a value much lower than that required to initiate foldback. This load "hysteresis" is a normal aspect of any type of current limit foldback associated with voltage regulators.

If the frequency synchronization feature is used, the current limit frequency fold-back is not operational, and the system may not survive a hard short-circuit at the output.

The safe operating areas, when in short circuit mode, are shown in [Figure 3](#) through [Figure 5](#), for different switching frequencies. Operating points below and to the right of the curve represent safe operation. Note that these curves are not valid when the LM22677 is in frequency synchronization mode.

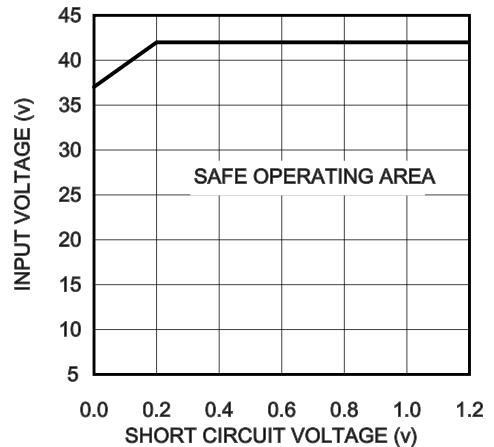

30074192

FIGURE 3. SOA at 300 kHz

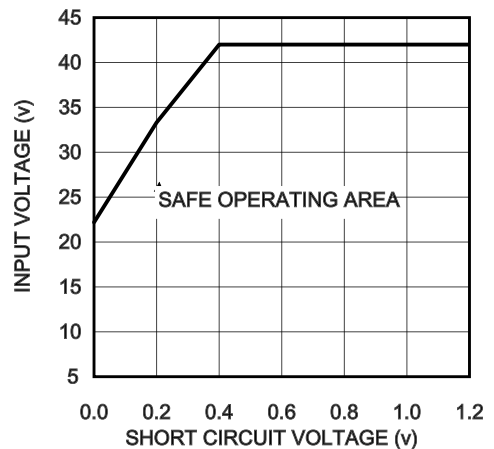

30074190

FIGURE 4. SOA at 500 kHz

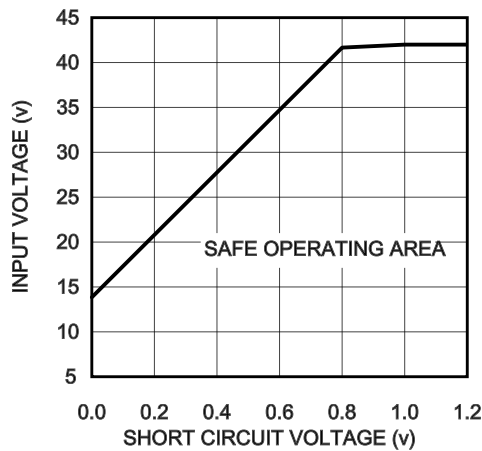

30074191

FIGURE 5. SOA at 800 kHz

Soft-Start

The soft-start feature allows the regulator to gradually reach steady-state operation, thus reducing start-up stresses. The internal soft-start feature brings the output voltage up in about 500 μ s. This time is fixed and can not be changed. Soft-start is reset any time the part is shut down or a thermal overload event occurs.

Switching Frequency Adjustment and Synchronization

The LM22677 will operate in three different modes, depending on the condition of the RT/SYNC pin. With the RT/SYNC pin floating, the regulator will switch at the internally set frequency of 500 kHz (typ.). With a resistor in the range of 25 k Ω to 200 k Ω , connected from RT/SYNC to ground, the internal switching frequency can be adjusted from 1MHz to 200 kHz. Figure 6 shows the typical curve for switching frequency vs. the external resistance connected to the RT/SYNC pin. The accuracy of the switching frequency, in this mode, is slightly worse than that of the internal oscillator; about +/- 25% is to be expected. Finally, an external clock can be applied to the RT/SYNC pin to allow the regulator to synchronize to a system clock or another LM22677. The mode is set during start-up of the regulator. When the LM22677 is enabled, or after V_{IN} is applied, a weak pull-up is connected to the RT/SYNC pin and, after approximately 100 μ s, the voltage on the pin is checked against a threshold of about 0.8V. With the RT/SYNC pin open, the voltage floats above this threshold, and the mode is set to run with the internal clock. With a frequency set resistor present, an internal reference holds the pin voltage at 0.8V; the resulting current sets the mode to allow the resistor to control the clock frequency. If the external circuit forces the RT/SYNC pin to a voltage much greater or less than 0.8V, the mode is set to allow external synchronization. The mode is latched until either the EN or the input supply is cycled.

The choice of switching frequency is governed by several considerations. As an example, lower frequencies may be desirable to reduce switching losses or improve duty cycle limits. Higher frequencies, or a specific frequency, may be desirable to avoid problems with EMI or reduce the physical size of external components. The flexibility of increasing the switching frequency above 500 kHz can also be used to op-

erate outside a critical signal frequency band for a given application. Keep in mind that the values of inductor and output capacitor cannot be reduced dramatically, by operating above 500 kHz. This is true because the design of the internal loop compensation restricts the range of these components.

Frequency synchronization requires some care. First the external clock frequency must be greater than the internal clock frequency, and less than 1 MHz. The maximum internal switching frequency is guaranteed in the Electrical Characteristics table. Note that the frequency adjust feature and the synchronization feature can not be used simultaneously. The synchronizing frequency must always be greater than the internal clock frequency. Secondly, the RT/SYNC pin must see a valid high or low voltage, during start-up, in order for the regulator to go into the synchronizing mode (see above). Also, the amplitude of the synchronizing pulses must comport with V_{SYNC} levels found in the Electrical Characteristics table. The regulator will synchronize on the rising edge of the external clock. If the external clock is lost during normal operation, the regulator will revert to the 500 kHz (typ.) internal clock.

If the frequency synchronization feature is used, current limit foldback is not operational; see the Current Limit section for details.

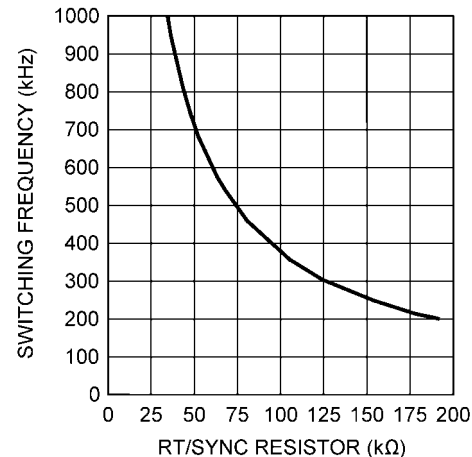

30074113

FIGURE 6. Switching Frequency vs RT/SYNC Resistor

Self Synchronization

It is possible to synchronize multiple LM22677 regulators together to share the same switching frequency. This can be done by tying the RT/SYNC pins together through a MOSFET and connecting a 1 k Ω resistor to ground at each pin. Figure 7 shows this connection. The gate of the MOSFET should be connected to the regulator with the highest output voltage. Also, the EN pins of both regulators should be tied to the common system enable, in order to properly initialize both regulators. The operation is as follows: When the regulators are enabled, the outputs are low and the MOSFET is off. The 1 k Ω resistors pull the RT/SYNC pins low, thus enabling the synchronization mode. These resistors are small enough to pull the RT/SYNC pin low, rather than activate the frequency adjust mode. Once the output voltage of one of the regulators is sufficient to turn on the MOSFET, the two RT/SYNC pins are tied together and the regulators will run in synchronization mode. The two regulators will be clocked at the same frequency but slightly phase shifted according to the minimum off-time of the regulator with the fastest internal oscillator. The

slight phase shift helps to reduce stress on the input capacitors of the regulator. It is important to choose a MOSFET with a low gate threshold voltage so that the MOSFET will be fully enhanced. Also, a MOSFET with low inter-electrode capacitance is required. The 2N7002 is a good choice.

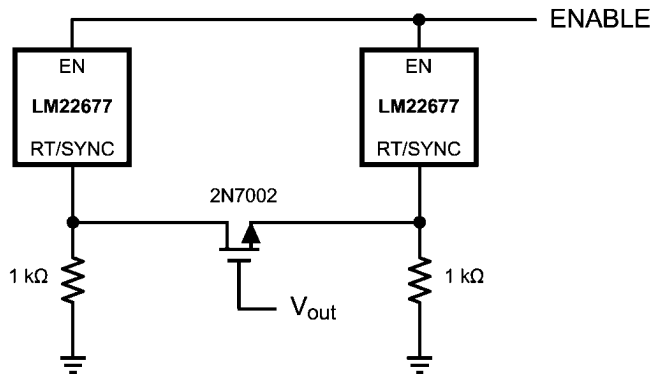

30074176

FIGURE 7. Self Synchronizing Setup

Boot-Strap Supply

The LM22677 incorporates a floating high-side gate driver to control the power MOSFET. The supply for this driver is the external boot-strap capacitor connected between the BOOT pin and SW. A good quality 10 nF ceramic capacitor must be connected to these pins with short, wide PCB traces. One reason the regulator imposes a minimum off-time is to ensure that this capacitor recharges every switching cycle. A minimum load of about 5 mA is required to fully recharge the boot-strap capacitor in the minimum off-time. Some of this load can be provided by the output voltage divider, if used.

Thermal Protection

Internal thermal shutdown circuitry protects the LM22677 should the maximum junction temperature be exceeded. This protection is activated at about 150°C, with the result that the regulator will shutdown until the temperature drops below about 135°C.

Internal Compensation

The LM22677 has internal loop compensation designed to provide a stable regulator over a wide range of external power stage components. The internal compensation of the -ADJ option is optimized for output voltages below 5V. If an output voltage of 5V or greater is needed, the -5.0 option with an external resistor divider can be used.

Ensuring stability of a design with a specific power stage (inductor and output capacitor) can be tricky. The LM22677 stability can be verified using the WEBENCH® Designer online circuit simulation tool at www.ti.com. A quick start spreadsheet can also be downloaded from the online product folder.

The complete transfer function for the regulator loop is found by combining the compensation and power stage transfer functions. The LM22677 has internal type III loop compensation, as detailed in Figure 8. This is the approximate "straight line" function from the FB pin to the input of the PWM modu-

lator. The power stage transfer function consists of a D.C. gain and a second order pole created by the inductor and output capacitor(s). Due to the input voltage feedforward employed in the LM22677, the power stage D.C. gain is fixed at 20dB. The second order pole is characterized by its resonant frequency and its quality factor (Q). For a first pass design, the product of inductance and output capacitance should conform to the following equation:

$$L \cdot C_{out} \approx 1.1 \times 10^{-9}$$

Alternatively, this pole should be placed between 1.5kHz and 15kHz and is given by the equation shown below:

$$F_o = \frac{1}{2\pi \cdot \sqrt{L \cdot C_{out}}}$$

The Q factor depends on the parasitic resistance of the power stage components and is not typically in the control of the designer. Of course, loop compensation is only one consideration when selecting power stage components; see the Application Information section for more details.

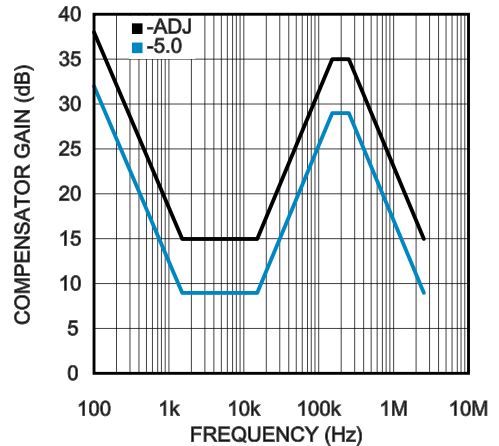

30074183

FIGURE 8. Compensator Gain

In general, hand calculations or simulations can only aid in selecting good power stage components. Good design practice dictates that load and line transient testing should be done to verify the stability of the application. Also, Bode plot measurements should be made to determine stability margins. Application note AN-1889 shows how to perform a loop transfer function measurement with only an oscilloscope and function generator.

Application Information

TYPICAL BUCK REGULATOR APPLICATION

Figure 9 shows an example of converting an input voltage range of 5.5V to 42V, to an output of 3.3v at 5 Amp. See AN-1892 for more information.

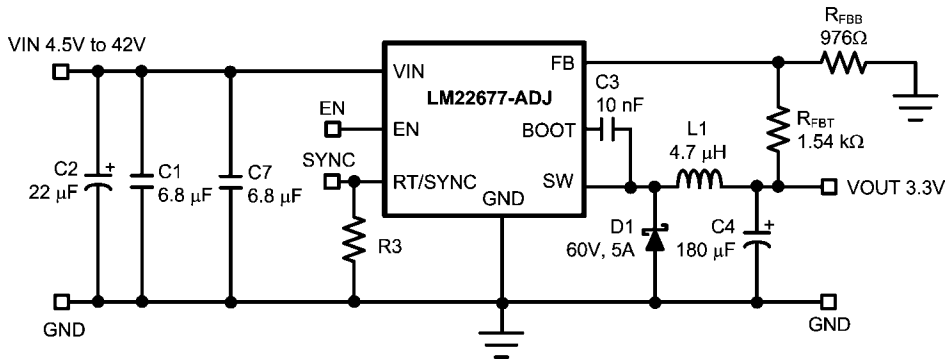

FIGURE 9. Typical Buck Regulator Application

EXTERNAL COMPONENTS

The following guidelines should be used when designing a step-down (buck) converter with the LM22677.

INDUCTOR

The inductor value is determined based on the load current, ripple current, and the minimum and maximum input voltages. To keep the application in continuous conduction mode (CCM), the maximum ripple current, I_{RIPPLE} , should be less than twice the minimum load current.

The general rule of keeping the inductor current peak-to-peak ripple around 30% of the nominal output current is a good compromise between excessive output voltage ripple and excessive component size and cost. Using this value of ripple current, the value of inductor, L , is calculated using the following formula:

$$L = \frac{(V_{\text{in}} - V_{\text{out}}) \cdot V_{\text{out}}}{0.3 \cdot I_{\text{out}} \cdot F_{\text{sw}} \cdot V_{\text{in}}}$$

where F_{sw} is the switching frequency and V_{in} should be taken at its maximum value, for the given application. The above formula provides a guide to select the value of the inductor L ; the nearest standard value will then be used in the circuit.

Once the inductor is selected, the actual ripple current can be found from the equation shown below:

$$\Delta I = \frac{(V_{\text{in}} - V_{\text{out}}) \cdot V_{\text{out}}}{L \cdot F_{\text{sw}} \cdot V_{\text{in}}}$$

Increasing the inductance will generally slow down the transient response but reduce the output voltage ripple. Reducing the inductance will generally improve the transient response but increase the output voltage ripple.

The inductor must be rated for the peak current, I_{PK} , in a given application, to prevent saturation. During normal loading conditions, the peak current is equal to the load current plus 1/2 of the inductor ripple current.

During an overload condition, as well as during certain load transients, the controller may trip current limit. In this case the peak inductor current is given by I_{CL} , found in the Electrical Characteristics table. Good design practice requires that the inductor rating be adequate for this overload condition. **If the inductor is not rated for the maximum expected current,**

it can saturate resulting in damage to the LM22677 and/or the power diode.

INPUT CAPACITOR

The input capacitor selection is based on both input voltage ripple and RMS current. Good quality input capacitors are necessary to limit the ripple voltage at the VIN pin while supplying most of the regulator current during switch on-time. Low ESR ceramic capacitors are preferred. Larger values of input capacitance are desirable to reduce voltage ripple and noise on the input supply. This noise may find its way into other circuitry, sharing the same input supply, unless adequate bypassing is provided. A very approximate formula for determining the input voltage ripple is shown below:

$$V_{\text{ri}} \approx \frac{I_{\text{out}}}{4 \cdot F_{\text{sw}} \cdot C_{\text{in}}}$$

Where V_{ri} is the peak-to-peak ripple voltage at the switching frequency. Another concern is the RMS current passing through this capacitor. The following equation gives an approximation to this current:

$$I_{\text{rms}} \approx \frac{I_{\text{out}}}{2}$$

The capacitor must be rated for at least this level of RMS current at the switching frequency.

All ceramic capacitors have large voltage coefficients, in addition to normal tolerances and temperature coefficients. To help mitigate these effects, multiple capacitors can be used in parallel to bring the minimum capacitance up to the desired value. This may also help with RMS current constraints by sharing the current among several capacitors. Many times it is desirable to use an electrolytic capacitor on the input, in parallel with the ceramics. The moderate ESR of this capacitor can help to damp any ringing on the input supply caused by long power leads. This method can also help to reduce voltage spikes that may exceed the maximum input voltage rating of the LM22677.

It is good practice to include a high frequency bypass capacitor as close as possible to the LM22677. This small case size, low ESR, ceramic capacitor should be connected directly to the VIN and GND pins with the shortest possible PCB traces. Values in the range of 0.47 μF to 1 μF are appropriate. This

capacitor helps to provide a low impedance supply to sensitive internal circuitry. It also helps to suppress any fast noise spikes on the input supply that may lead to increased EMI.

OUTPUT CAPACITOR

The output capacitor is responsible for filtering the output voltage and supplying load current during transients. Capacitor selection depends on application conditions as well as ripple and transient requirements. Best performance is achieved with a parallel combination of ceramic capacitors and a low ESR SP™ or POSCAP™ type. Very low ESR capacitors such as ceramics reduce the output ripple and noise spikes, while higher value electrolytics or polymers provide large bulk capacitance to supply transients. Assuming very low ESR, the following equation gives an approximation to the output voltage ripple:

$$V_{ro} \approx \frac{(V_{in} - V_{out}) \cdot V_{out}}{8 \cdot V_{in}} \cdot \frac{1}{F_{sw}^2 \cdot L \cdot C_{out}}$$

Typically, a total value of 100 μ F, or greater, is recommended for output capacitance.

In applications with V_{out} less than 3.3V, it is critical that low ESR output capacitors are selected. This will limit potential output voltage overshoots as the input voltage falls below the device normal operating range.

If the switching frequency is set higher than 500 kHz, the capacitance value may not be reduced proportionally due to stability requirements. The internal compensation is optimized for circuits with a 500 kHz switching frequency. See the Internal Loop Compensation section for more details.

BOOT-STRAP CAPACITOR

The bootstrap capacitor between the BOOT pin and the SW pin supplies the gate current to turn on the N-channel MOSFET. The recommended value of this capacitor is 10 nF and should be a good quality, low ESR ceramic capacitor.

In some cases it may be desirable to slow down the turn-on of the internal power MOSFET, in order to reduce EMI. This can be done by placing a small resistor in series with the C_{boot} capacitor. Resistors in the range of 10 Ω to 50 Ω can be used. This technique should only be used when absolutely necessary, since it will increase switching losses and thereby reduce efficiency.

OUTPUT VOLTAGE DIVIDER SELECTION

For output voltages between about 1.285V and 5V, the -ADJ option should be used, with an appropriate voltage divider as shown in [Figure 10](#). The following equation can be used to calculate the resistor values of this divider:

$$R_{FBT} = \left[\frac{V_{out}}{1.285} - 1 \right] \cdot R_{FBB}$$

A good value for R_{FBB} is 1k Ω . This will help to provide some of the minimum load current requirement and reduce susceptibility to noise pick-up. The top of R_{FBT} should be connected directly to the output capacitor or to the load for remote sensing. If the divider is connected to the load, a local high-frequency bypass should be provided at that location.

For output voltages of 5V, the -5.0 option should be used. In this case no divider is needed and the FB pin is connected to the output. The approximate values of the internal voltage divider are as follows: 7.38k Ω from the FB pin to the input of the error amplifier and 2.55k Ω from there to ground.

Both the -ADJ and -5.0 options can be used for output voltages greater than 5V, by using the correct output divider. As mentioned in the Internal Loop Compensation section, the -5.0 option is optimized for output voltages of 5V. However, for output voltages greater than 5V, this option may provide better loop bandwidth than the -ADJ option, in some applications. If the -5.0 option is to be used at output voltages greater than 5V, the following equation should be used to determine the resistor values in the output divider:

$$R_{FBT} = \frac{R_{FBB} \cdot (V_{out} - 5)}{5 + R_{FBB} \cdot 5 \times 10^{-4}}$$

Again a value of R_{FBB} of about 1k Ω is a good first choice.

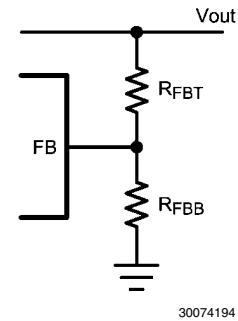

FIGURE 10. Resistive Feedback Divider

A maximum value of 10 k Ω is recommended for the sum of R_{FBB} and R_{FBT} to maintain good output voltage accuracy for the -ADJ option. A maximum of 2 k Ω is recommended for the -5.0 option. For the -5.0 option, the total internal divider resistance is typically 9.93 k Ω .

In all cases the output voltage divider should be placed as close as possible to the FB pin of the LM22677; since this is a high impedance input and is susceptible to noise pick-up.

POWER DIODE

A Schottky type power diode is required for all LM22677 applications. Ultra-fast diodes are not recommended and may result in damage to the IC due to reverse recovery current transients. The near ideal reverse recovery characteristics and low forward voltage drop of Schottky diodes are particularly important for high input voltage and low output voltage applications common to the LM22677. The reverse breakdown rating of the diode should be selected for the maximum V_{IN} , plus some safety margin. A good rule of thumb is to select a diode with a reverse voltage rating of 1.3 times the maximum input voltage.

Select a diode with an average current rating at least equal to the maximum load current that will be seen in the application.

Circuit Board Layout

Board layout is critical for the proper operation of switching power supplies. First, the ground plane area must be sufficient for thermal dissipation purposes. Second, appropriate guidelines must be followed to reduce the effects of switching noise. Switch mode converters are very fast switching devices. In such cases, the rapid increase of input current combined with the parasitic trace inductance generates unwanted $L di/dt$ noise spikes. The magnitude of this noise tends to increase as the output current increases. This noise may turn into electromagnetic interference (EMI) and can also cause problems in device performance. Therefore, care must be taken in layout to minimize the effect of this switching noise.

The most important layout rule is to keep the AC current loops as small as possible. [Figure 11](#) shows the current flow in a buck converter. The top schematic shows the current flow during the FET switch on-state. The middle schematic shows the current flow during the FET switch off-state.

The bottom schematic shows the currents referred to as AC currents. These AC currents are the most critical since they are changing in a very short time period. The dotted lines of the bottom schematic are the traces to keep as short and wide as possible. This will also yield a small loop area reducing the loop inductance. To avoid functional problems due to layout, review the PCB layout example. Best results are achieved if the placement of the LM22677, the bypass capacitor, the Schottky diode, R_{FBB} , R_{FBT} and the inductor are placed as shown in the example. Note that, in the layout shown, $R1 = R_{FBB}$ and $R2 = R_{FBT}$. It is also recommended to use 2oz copper boards or heavier to help thermal dissipation and to reduce the parasitic inductances of board traces. See application note AN-1229 for more information.

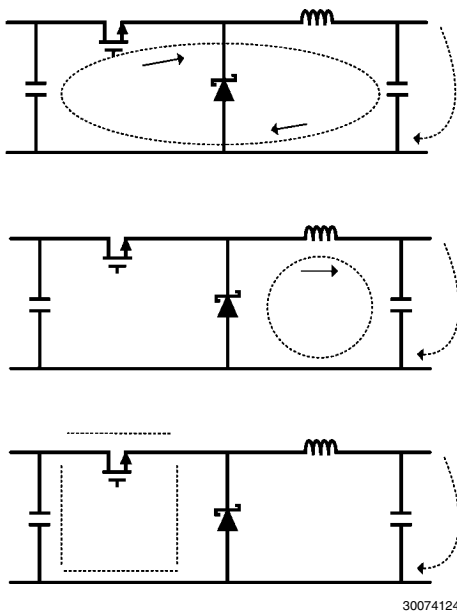

FIGURE 11. Current Flow in a Buck Application

Thermal Considerations

The components with the highest power dissipation are the power diode and the power MOSFET internal to the LM22677 regulator. The easiest method to determine the power dissipation within the LM22677 is to measure the total conversion losses then subtract the power losses in the diode and inductor. The total conversion loss is the difference between the input power and the output power. An approximation for the power diode loss is:

$$P_D = I_{out} \cdot V_D \cdot \left[1 - \frac{V_{out}}{V_{in}} \right]$$

Where V_D is the diode voltage drop. An approximation for the inductor power is:

$$P_L = I_{out}^2 \cdot R_L \cdot 1.1$$

where R_L is the DC resistance of the inductor and the 1.1 factor is an approximation for the AC losses.

The regulator has an exposed thermal pad to aid power dissipation. Adding multiple vias under the device to the ground plane will greatly reduce the regulator junction temperature. Selecting a diode with an exposed pad will also aid the power dissipation of the diode. The most significant variables that affect the power dissipation of the regulator are output current, input voltage and operating frequency. The power dissipated while operating near the maximum output current and maximum input voltage can be appreciable. The junction-to-ambient thermal resistance of the LM22677 will vary with the application. The most significant variables are the area of copper in the PC board, the number of vias under the IC exposed pad and the amount of forced air cooling provided. A large continuous ground plane on the top of bottom PCB layer will provide the most effective heat dissipation. The integrity of the solder connection from the IC exposed pad to the PC board is critical. Excessive voids will greatly diminish the thermal dissipation capacity. The junction-to-ambient thermal resistance of the LM22677 TO-263 Thin package is specified in the Electrical Characteristics table. See application note AN-2020 for more information.

PCB Layout Example

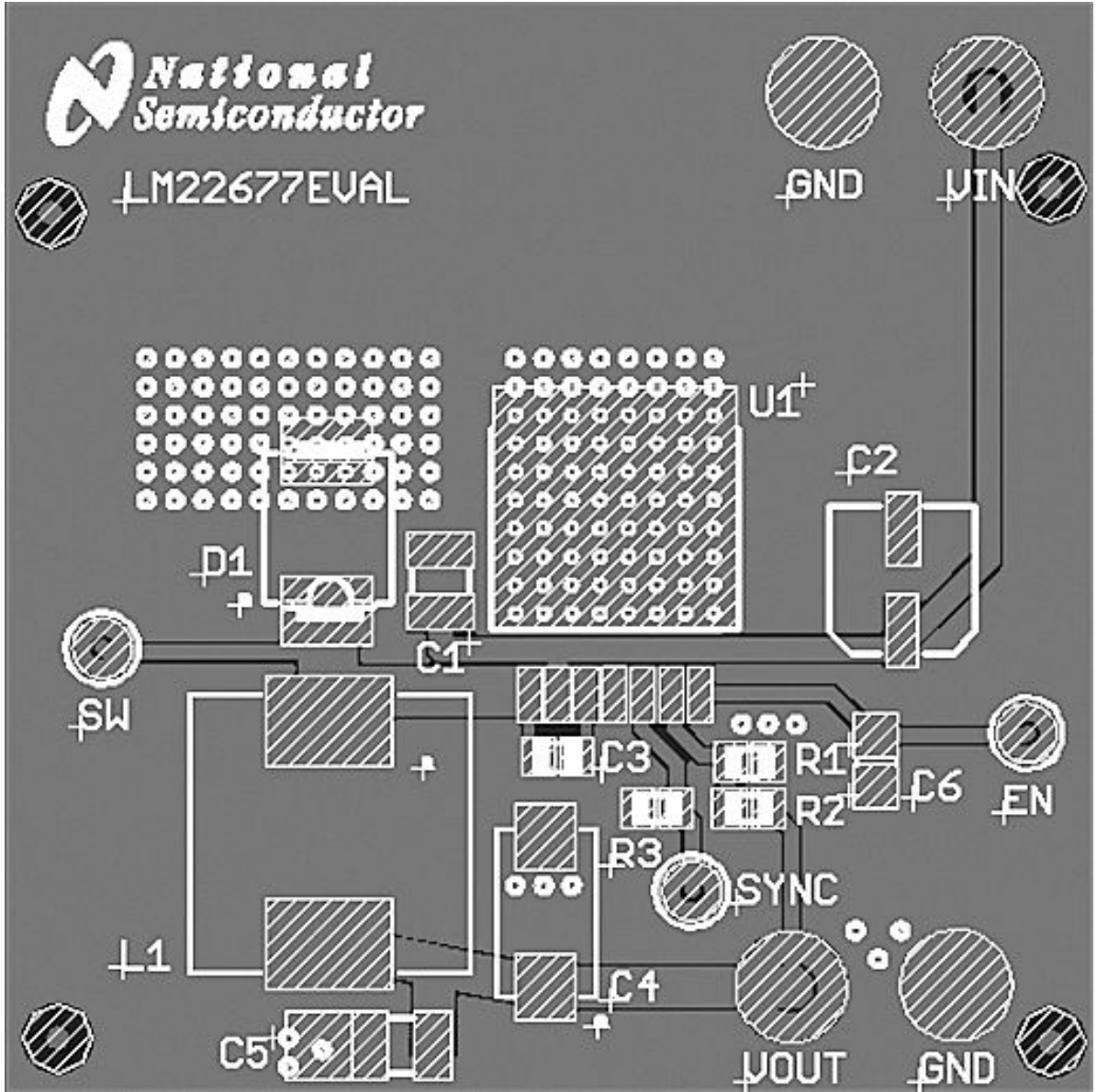

30074125

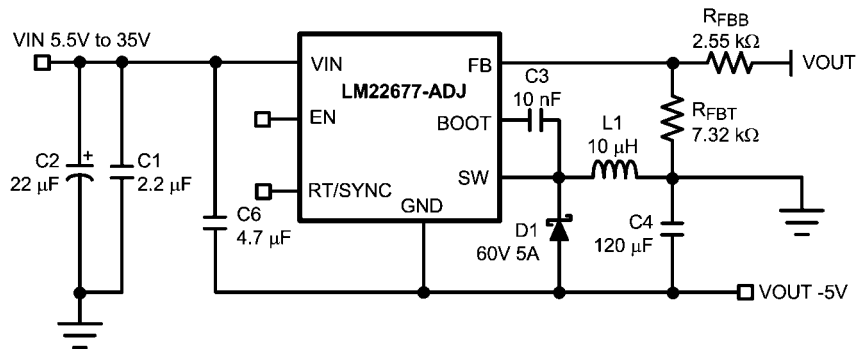

30074198

FIGURE 12. Inverting Regulator Application

Physical Dimensions inches (millimeters) unless otherwise noted

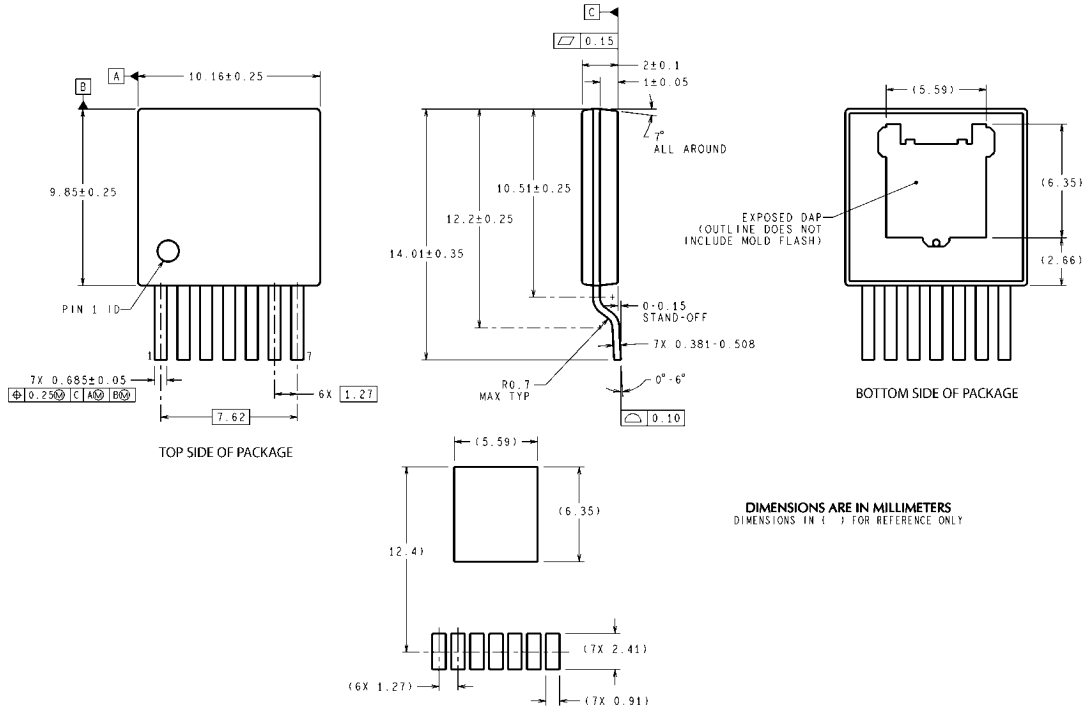

**7-Lead Plastic TO-263 THIN Package
TI Package Number TJ7A**

TJ7A (Rev D)

Notes

LM22677/LM22677Q

Notes

IMPORTANT NOTICE

Texas Instruments Incorporated and its subsidiaries (TI) reserve the right to make corrections, modifications, enhancements, improvements, and other changes to its products and services at any time and to discontinue any product or service without notice. Customers should obtain the latest relevant information before placing orders and should verify that such information is current and complete. All products are sold subject to TI's terms and conditions of sale supplied at the time of order acknowledgment.

TI warrants performance of its hardware products to the specifications applicable at the time of sale in accordance with TI's standard warranty. Testing and other quality control techniques are used to the extent TI deems necessary to support this warranty. Except where mandated by government requirements, testing of all parameters of each product is not necessarily performed.

TI assumes no liability for applications assistance or customer product design. Customers are responsible for their products and applications using TI components. To minimize the risks associated with customer products and applications, customers should provide adequate design and operating safeguards.

TI does not warrant or represent that any license, either express or implied, is granted under any TI patent right, copyright, mask work right, or other TI intellectual property right relating to any combination, machine, or process in which TI products or services are used. Information published by TI regarding third-party products or services does not constitute a license from TI to use such products or services or a warranty or endorsement thereof. Use of such information may require a license from a third party under the patents or other intellectual property of the third party, or a license from TI under the patents or other intellectual property of TI.

Reproduction of TI information in TI data books or data sheets is permissible only if reproduction is without alteration and is accompanied by all associated warranties, conditions, limitations, and notices. Reproduction of this information with alteration is an unfair and deceptive business practice. TI is not responsible or liable for such altered documentation. Information of third parties may be subject to additional restrictions.

Resale of TI products or services with statements different from or beyond the parameters stated by TI for that product or service voids all express and any implied warranties for the associated TI product or service and is an unfair and deceptive business practice. TI is not responsible or liable for any such statements.

TI products are not authorized for use in safety-critical applications (such as life support) where a failure of the TI product would reasonably be expected to cause severe personal injury or death, unless officers of the parties have executed an agreement specifically governing such use. Buyers represent that they have all necessary expertise in the safety and regulatory ramifications of their applications, and acknowledge and agree that they are solely responsible for all legal, regulatory and safety-related requirements concerning their products and any use of TI products in such safety-critical applications, notwithstanding any applications-related information or support that may be provided by TI. Further, Buyers must fully indemnify TI and its representatives against any damages arising out of the use of TI products in such safety-critical applications.

TI products are neither designed nor intended for use in military/aerospace applications or environments unless the TI products are specifically designated by TI as military-grade or "enhanced plastic." Only products designated by TI as military-grade meet military specifications. Buyers acknowledge and agree that any such use of TI products which TI has not designated as military-grade is solely at the Buyer's risk, and that they are solely responsible for compliance with all legal and regulatory requirements in connection with such use.

TI products are neither designed nor intended for use in automotive applications or environments unless the specific TI products are designated by TI as compliant with ISO/TS 16949 requirements. Buyers acknowledge and agree that, if they use any non-designated products in automotive applications, TI will not be responsible for any failure to meet such requirements.

Following are URLs where you can obtain information on other Texas Instruments products and application solutions:

Products

Audio	www.ti.com/audio
Amplifiers	amplifier.ti.com
Data Converters	dataconverter.ti.com
DLP® Products	www.dlp.com
DSP	dsp.ti.com
Clocks and Timers	www.ti.com/clocks
Interface	interface.ti.com
Logic	logic.ti.com
Power Mgmt	power.ti.com
Microcontrollers	microcontroller.ti.com
RFID	www.ti-rfid.com
OMAP Mobile Processors	www.ti.com/omap
Wireless Connectivity	www.ti.com/wirelessconnectivity

Applications

Automotive and Transportation	www.ti.com/automotive
Communications and Telecom	www.ti.com/communications
Computers and Peripherals	www.ti.com/computers
Consumer Electronics	www.ti.com/consumer-apps
Energy and Lighting	www.ti.com/energy
Industrial	www.ti.com/industrial
Medical	www.ti.com/medical
Security	www.ti.com/security
Space, Avionics and Defense	www.ti.com/space-avionics-defense
Video and Imaging	www.ti.com/video

TI E2E Community Home Page

e2e.ti.com

Mailing Address: Texas Instruments, Post Office Box 655303, Dallas, Texas 75265
Copyright © 2012, Texas Instruments Incorporated